

AVK Surface Boxes





The Story Behind AVK Surface Boxes

Since 1986 AVK Plastics has been involved in the development, manufacturing, and sales of synthetic Surface Boxes. To date more than 3 million AVK synthetic Surface Boxes have been produced and successfully installed throughout the world.

Advantages

Apart from its economical benefits the AVK Surface Boxes offer advantages like being lightweight, easy to handle, and maintenance free. Moreover, the synthetic housing has, unlike the cast iron version, an impact and a sound absorbing effect which reduces the noise of the lid. The housing and the lid will not seize which ensures easy access throughout the year.

Quality

AVK has earned a reputation for service and quality, and continually strives to satisfy the expectations of its customers. Our quality process starts with the high acceptance criteria applied to the purchase of raw materials, extends to control of production processes, and ends with a comprehensive and precisely defined series of tests and quality evaluations. In this way AVK ensures that only quality products are released on the market.

The AVK Quality Department is equipped with advanced testing and analytical equipment, and our Quality Management System is certified according to EN ISO 9001.



**DVGW Approved
According to VP 310-2**

Environmentally friendly

The production of synthetic Surface Boxes is far more environmentally friendly than the production of cast iron Surface Boxes. Compared with metal, the energy use from resource to end product in the production of synthetic Surface Boxes is relatively small. In figures, the result of energy saving is 81% compared to cast iron Surface Boxes. This makes the AVK Surface Boxes ecologically sound!

Material

The lifetime of a Surface Box and the ability to withstand sustained static and dynamic loads over decades depends on proper installation.

AVK has, in close collaboration with the Dutch Institute for Synthetic Materials (TNO), selected a PA based material for the construction of the Surface Boxes. The specially compounded PA resin has clearly defined characteristics and reliable long-term behaviour which provides optimal conditions against road traffic all year round. It especially secures resistance against high impact forces at low temperatures and offers sufficient heat resistance for safe installation in hot rolled asphalt.

Standard

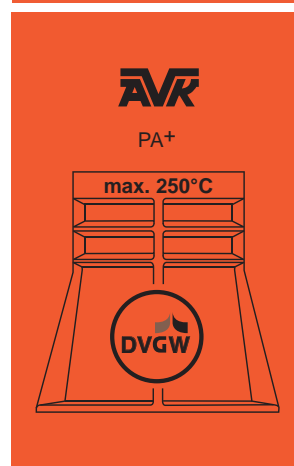

Height adjustable

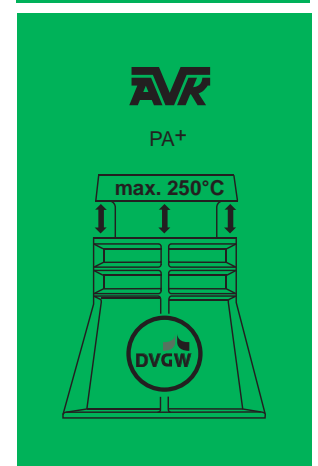



Field of Application

The wide range of AVK Surface Boxes can be used in many fields of application, valves, hydrants, groundwater exploration, irrigation equipment and measurement equipment, because of its variety of dimensions.

Valves

Surface Boxes are generally installed to give access to and operate buried valves. They can be used in main and service pipe applications for water and sewerage. Between valve and Surface Box there is, depending on the depth, an extension spindle, provided with a protection sleeve.

Hydrants

Underground hydrants are usually installed with a riser on the main pipe. The head of the hydrant is equipped with an operating spindle and a connection for a standpipe ending in a Surface Box.

Other Uses

Groundwater exploration, irrigation equipment, and measurement equipment.

Installation

The installation of synthetic Surface Boxes, both standard and height adjustable types, is similar to the installation of cast iron Surface Boxes.

One of the important advantages of the synthetic Surface Box is being lightweight and easy to install. Correct installation is a precondition for an optimum lifetime of the Surface Box. In order to improve the bearing load, it is recommended to apply a support tile.

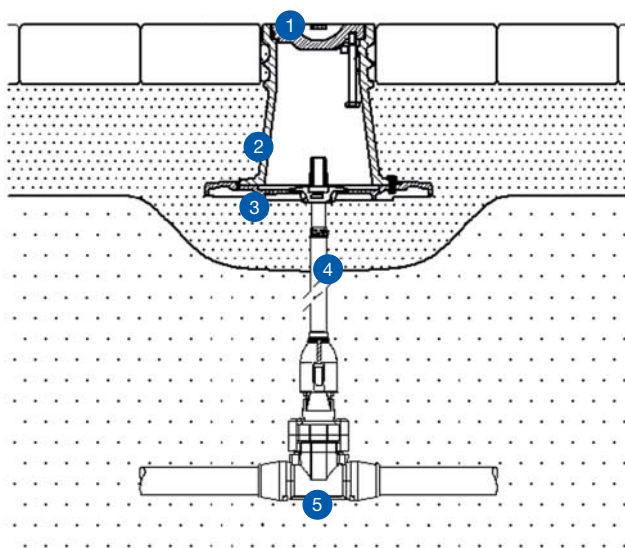

1. GG-20 Lid
2. PA+ housing

3. Support tile
4. Extension spindle

5. Valve

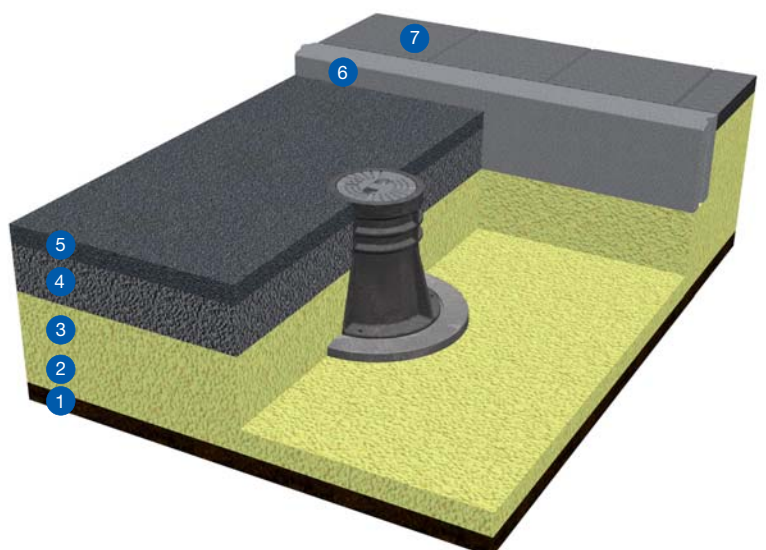

1. Subsoil
2. First sand layer
3. Second sand layer

4. First asphalt layer
5. Second asphalt layer
6. Curb

7. Pavement

Features



Why choose synthetic Surface Boxes in general?

- Material combination, noiseless.
- Maintenance free.
- Low weight.
- Easy handling.
- Lid of cast iron does not seize on the synthetic body.
- Design with ribs ensures optimal stability in road foundation.
- Environmentally friendly.
- Economic use of energy resources, recyclable.

Why choose synthetic Surface Boxes from AVK?

- AVK is a market leader in synthetic Surface Boxes.
- AVK has 20 years of experience in the production of Surface Boxes.
- AVK products are certified according to international standards
- AVK offers a complete range of products.



Standard



Height adjustable



Lockable



Surface Boxes Water & Sewage

Plastic Surface Boxes and accessories in synthetic material for the water supply industry.

Heat resistant up to 250°C
Housing in PA+
Lid in GG-20 cast iron
Bolt in stainless steel A2

Standard - DVGW Approved



Series 80/30
DIN 4055
for underground hydrants
Lid inscription: Hydrant
13.5 Kg
Ref. nos.: 80-3003200



Series 80/31
DIN 4056
for valves
Lid inscription: W
6.5 Kg
Ref. nos.: 80-3103200



Series 80/32
DIN 4057
for service connection
valves
Lid inscription: W
3.5 Kg
Ref. nos.: 80-3203200

Height adjustable - DVGW Approved



Series 80/30
DIN 4055
for underground hydrants
Lid inscription: Hydrant
15.5 Kg
Ref. nos.: 80-3013000



Series 80/31
DIN 4056
for valves
Lid inscription: W
6.5 Kg
Ref. nos.: 80-3113000



Series 80/32
DIN 4057
for service connection
valves
Lid inscription: W
4.0 Kg
Ref. nos.: 80-3213000

Accessories



Series 80/46
for type
- 80/31
- 80/32
Ref. nos.: 80-4600000



Series 80/46
for type
- 80/31
- 80/32
with spindle fixation
Ref. nos.: 80-4600001



Series 80/46
for type
- 80/30
Ref. nos.: 80-4600005

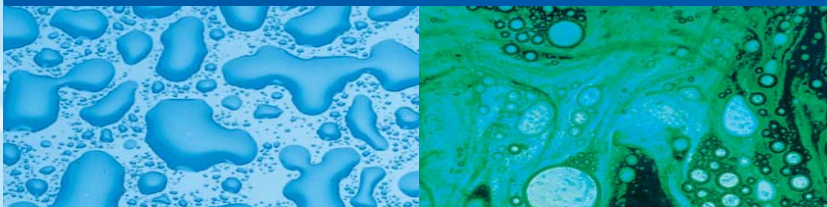

The Surface Box, with support tile, is a part of the

Total AVK Solution

With extension spindle
and service connection or gate valve



559A Grand Junction Road
Wingfield SA 5013 Australia
Telephone +61 8 8368 0900
Telefax +61 8 8368 0970
e-mail: info@avkvalves.com.au
www.avkvalves.com.au

February 2008